

Orbotech Nuvogo™ 80H/80HXL

Mass Production, Fine Line Direct Imaging (DI)



Orbotech Nuvogo 80H/80HXL

Orbotech Nuvogo 80H/80HXL is a mass production, high capacity, direct imaging solution, optimized for HDI, advanced MLB, flex and rigid-flex PCBs. With KLA's field-proven Large Scan Optics (LSO)™ Technology, MultiWave Laser™ Technology and advanced scaling algorithms, Orbotech Nuvogo 80H/80HXL ensures high imaging quality and accuracy. It enables high capacity of up to 7,000 panels per day per line, even for less sensitive resists, reducing the total cost of ownership (TCO) while maintaining optimal quality at a high speed.

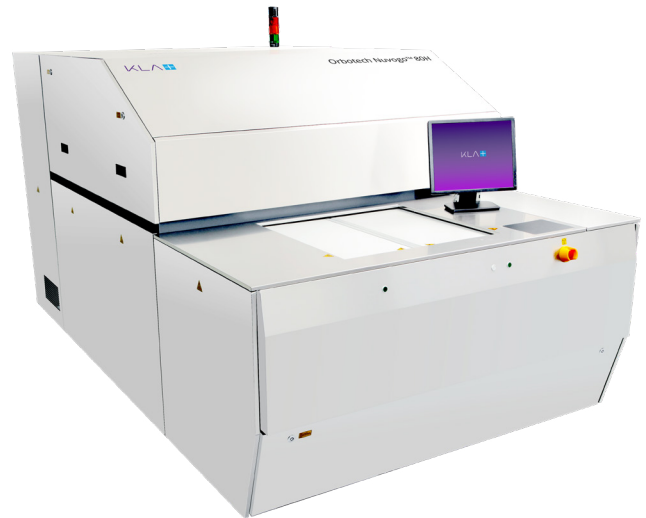

Benefits

Mass Production Digital Imaging

- High capacity: up to 7,000 panels/day/line
- Fast target acquisition ensuring high efficiency
- Optimized imaging time with dual table transport mechanism

High Imaging Quality

- Unique optics design for optimal line structure down to 15/15µm L/S
- High depth-of-focus (DOF) for challenging topographies
- Advanced scaling modes for optimal registration ($\pm 10\mu\text{m}$)

High Efficiency

- Compatible with a wide range of resists and processes
- Effective job queue management for maximum productivity
- Automation ready for seamless production

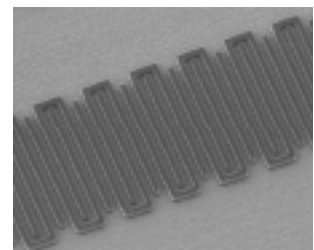
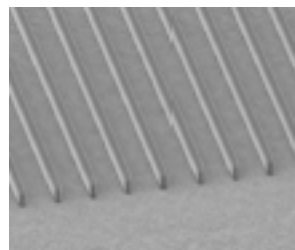
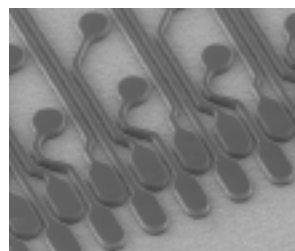

Fine lines/spaces down to 15/15µm

Technologies



LSO™ Technology



MultiWave Laser™ Technology

High Imaging Quality

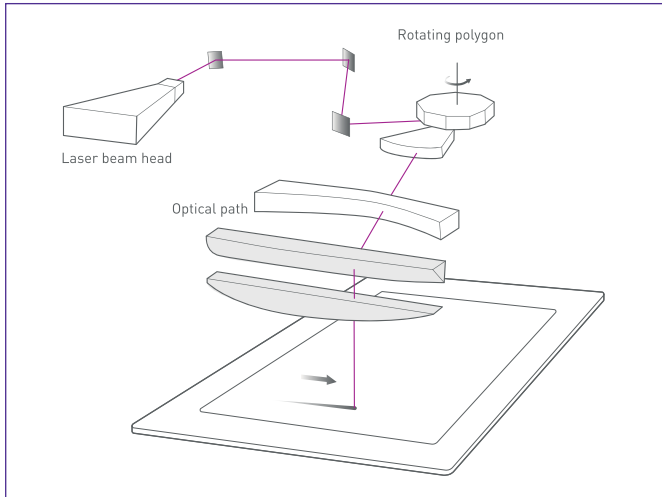

Superior line structure in a single scan enabled by KLA's LSO™ technology

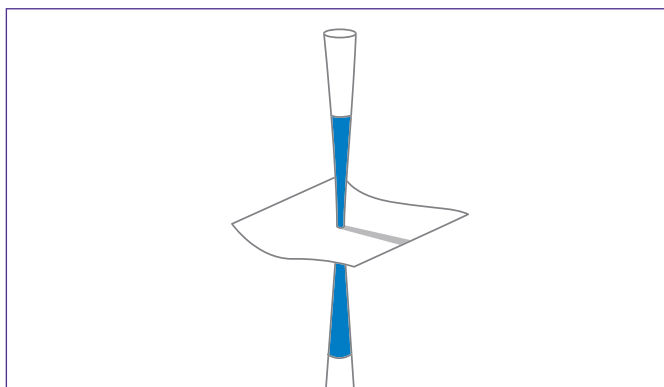

High Depth-of-Focus (DOF) for challenging topographies

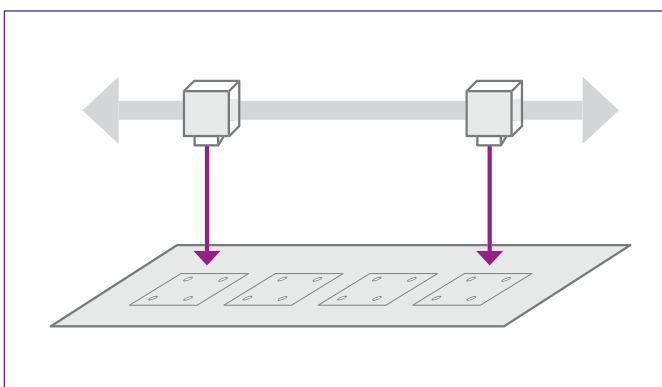

On-the-fly target recognition and acquisition

High Resists Flexibility

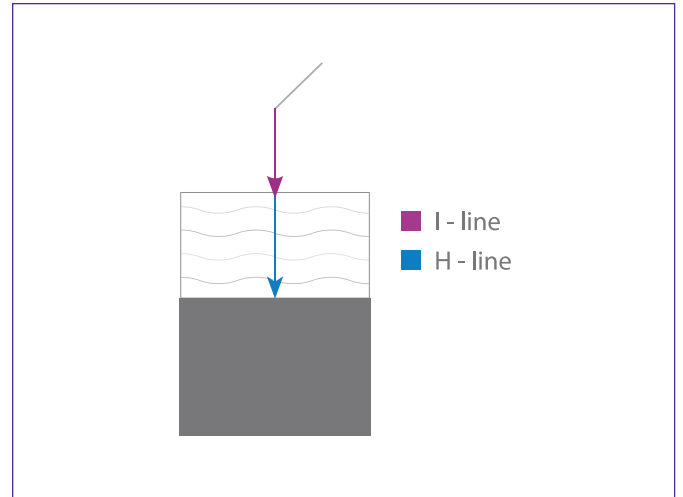

Compatibility with a wide range of resists and processes driven by KLA's MultiWave Laser™ technology

Advanced Scaling Modes

- Wise Scaling – best scaling mode for mass production, achieving highest panel unification in the batch
- Auto scaling/fixed scaling/group scaling
- Partial Scaling – sub-area registration for thin core layers
- Extremely fast target acquisition enables minimum throughput loss

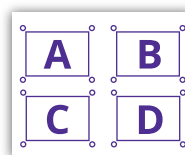

CAM data

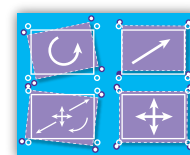

Panel

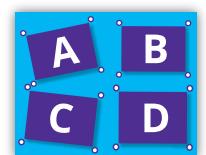

Imaging

Traceability

Enables panel tracking by marking: serial number stamp; sub-panel and PCB; date and time stamp; scaling stamp and machine ID by alphanumeric stamping or 1-D/2-D barcode (Data Matrix Code).

Specifications

	Orbotech Nuvogo 80H	Orbotech Nuvogo 80HXL
Maximum Throughput*	300 prints/h Imaging Size 24" x 18"	
Minimum Line/Space*	15/15µm	
Address Resolution	1.5µm	
Registration Accuracy FtG**	±10µm	
Side-to-Side Registration FtB**	20µm	
Maximum Substrate Size	635mm x 660mm 25" x 26"	660mm x 812mm 26" x 32"
Maximum Exposure Area	609.6mm x 660mm 24" x 26"	635mm x 812mm 25" x 32"
Substrate Thickness	0.025mm - 8mm	
Imaging Energy Range	25 - 2,200mJ/cm ²	

* Dependent on resist type and process

** All values are 3σ

The above specifications are subject to change without notification.

KLA SERVICES

From tool installation and system optimization to productivity enhancements and global supply chain management, KLA Services is a trusted partner to customers around the world — delivering an unrivaled experience focused on maximizing tool performance and availability.

© 2024 KLA Corporation. All rights reserved worldwide. KLA reserves the right to change the hardware and/or software specifications without notice. All brands or product/service names may be trademarks of their respective owners including but not limited to: KLA.

KLA Corporation
www.kla.com

Rev 1.0_09-05-2024